

Stud Bolts ASTM A193

Inch Series, UNC/UN – Dimensions

Notes:

1. The stud Bolts will generally conform to ASTM A193 Gr: B7
2. Thread will conform to Class 2A unified coarse threads as per ANSI B1.1
3. Material: Medium Carbon Chromium Molybdenum Steel, CR-Mo Alloy Steel (Cr-Mo).
4. Heat treatment: As per Grade 'B7'
5. All dimensions are in inches.

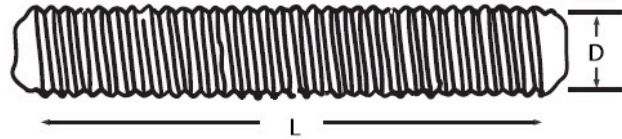

Chemical Analysis

C	Mn	P	S	Si	Cr	Mo
0.37	0.65			0.15	0.80	0.15
0.49	1.10	0.035	0.04	0.35	1.10	0.25

Mechanical Properties

	≤ 2 1/2" diameter
	ASTM A193 Grade B7
UTS, ksi (Mpa)	125
0.2% Proof Stress, ksi (Mpa)	105
% Elongation (min)	16
% Reduction of Area (min)	50
Hardness HBW (max)	321
Minimum Tempering Temperature, °C (°F)	593 (1100)

Nominal Thread Size 'D'	TPI		Length Range 'L'	Nominal Thread Size 'D'	TPI		Length Range 'L'
	UNC	UN			UNC	UN	
1/2"	13	-	up to 120"	2 3/8"	-	8	up to 50"
5/8"	11	-	up to 120"	2 1/2"	-	8	up to 60"
3/4"	10	-	up to 120"	2 5/8"	-	8	up to 60"
7/8"	9	-	up to 120"	2 3/4"	-	8	up to 60"
1"	8	-	up to 120"	2 7/8"	-	8	up to 60"
1 1/8"	-	8	up to 120"	3"	-	8	up to 48"
1 1/4"	-	8	up to 120"	3 1/8"	-	8	up to 48"
1 3/8"	-	8	up to 120"	3 1/4"	-	8	up to 48"
1 1/2"	-	8	up to 120"	3 3/8"	-	8	up to 48"
1 5/8"	-	8	up to 120"	3 1/2"	-	8	up to 48"
1 3/4"	-	8	up to 120"	3 5/8"	-	8	up to 48"
1 7/8"	-	8	up to 120"	3 3/4"	-	8	up to 48"
2"	-	8	up to 120"	3 7/8"	-	8	up to 48"
2 1/8"	-	8	up to 120"	4"	-	8	up to 48"
2 1/4"	-	8	up to 120"	-	-	-	-

Heavy Hexagon Nuts – ASTM A 194

Notes:

1. The nuts will generally conform to ANSI/ASME B18.2.2. Heavy Nuts
2. Thread will conform to Class 2B of ANSI B1.1
3. Material & Heat Treatment:
To achieve mechanical properties of Grade 2H which conform to the requirement of ASTM A194.
4. In Bolt/Nut assembly, tightening should be done by rotation of nut. Torque Value as recommended in tables for bolts.
5. All dimensions are in inches.

Dimensions

Thread Size	T.P.I UNC/UN	W Max.	C Max.	H Norm.
1/2"	13	0.875"	1.010"	0.484"
9/16"	12	0.938"	1.083"	0.547"
5/8"	11	1.062"	1.227"	0.609"
3/4"	10	1.250"	1.443"	0.734"
7/8"	9	1.438"	1.660"	0.859"
1"	8	1.625"	1.876"	0.984"
1 1/8"	8	1.812"	2.093"	1.109"
1 1/4"	8	2.000"	2.309"	1.219"
1 3/8"	8	2.188"	2.526"	1.344"
1 1/2"	8	2.375"	2.742"	1.469"
1 5/8"	8	2.562"	2.959"	1.594"
1 3/4"	8	2.750"	3.175"	1.719"
1 7/4"	8	2.938"	3.392"	1.844"
2"	8	3.125"	3.608"	1.969"
2 1/4"	8	3.500"	4.041"	2.203"
2 1/2"	8	3.875"	4.474"	2.453"
2 3/4"	8	4.250"	4.907"	2.953"
3"	8	4.625"	5.340"	2.953"
3 1/4"	8	5.000"	5.774"	3.188"
3 1/2"	8	5.375"	6.207"	3.438"

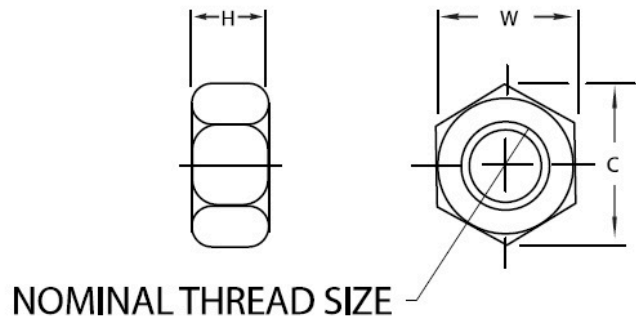

Grade	Size	For use with Bolts/Stud Bolts of Grade	Proof Load Stress (psi)	Rockwell Hardness (HR)
2H	up to 1 1/2" incl	ASTM A325 T-1	175,000	C24 – C38
2H	Over 1 1/2"	ASTM A 193 B7	175,000	B95 – C38