

DIN 86019
Seamless tubes made of CuNi10Fe1.6Mn for pipes -
Dimensions for standard tubes and precision tubes

Material: CuNi 90/10 CuNi 70/30

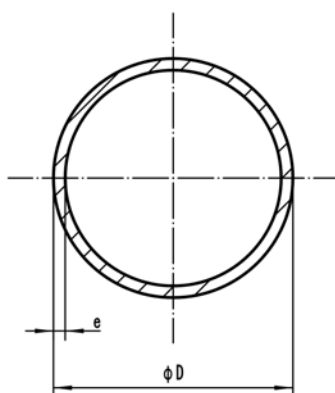

Outside diameter of pipe			DIN 86019				EEMUA 144			
			10 Bar		14 Bar		16 Bar		20 Bar	
ØD		Wall thickness	Theoretical weight	Wall thickness	Theoretical weight	Wall thickness	Theoretical weight	Wall thickness	Theoretical weight	
nominal	actual	actual	Kg/m	actual	Kg/m	actual	Kg/m	actual	Kg/m	
inch	ND	mm		mm		mm		mm		mm
0.125		10	1	0.26	1	0.26	1	0.26	1	0.26
0.25		12	1	0.31	1	0.31	1	0.31	1	0.31
0.38	10	16	1	0.42	1	0.42	2	0.79	2	0.79
0.5	15	20	1	0.53	1	0.53	2	1.01	2	1.01
0.75	20	25	1.5	0.99	1.5	0.99	2	1.3	2	1.3
1	25	30	1.5	1.2	1.5	1.2	2.5	1.93	2.5	1.93
1.25	32	38	1.5	1.54	1.5	1.54	2.5	2.5	2.5	2.5
1.5	40	44.5	1.5	1.81	1.5	1.81	2.5	2.95	2.5	2.95
2	50	57	1.5	2.34	1.5	2.34	2.5	3.83	2.5	3.83
2.5	65	76.1	2	4.16	2	4.16	2.5	5.17	2.5	5.17
3	80	88.9	2	4.88	2.5	6.07	2.5	6.07	2.5	6.07
4	100	108	2.5	7.41	2.5	7.41	3	8.85	3	8.85
5	125	133	2.5	9.16	3	10.95	3	10.95	3	10.95
6	150	159	2.5	10.99	3	13.14	3	13.14	3.5	15.29
7	175	193.7	2.5	13.43	3.5	18.7	3	16.07	3.5	18.7
8	200	219.1	3	18.21	3.5	21.19	4	24.17	4.5	27.12
10	250	267	3	22.24	4	29.55	4.5	33.18	5.5	40.39
12	300	323.9	4	35.94	5	44.78	5.5	49.18	7	62.3
14	350	368	4	40.89	5.5	56	6.5	65.99	8	80.89
16	400	419.1	4	46.62	6	69.6	7	81	9	103.64
18	450	457.2	4	50.91	6	76.03	8	100.93	9.5	119.45
20	500	508	4.5	63.63	6.5	91.55	8.5	119.24	11	153.54
24	600	610	5	84.96	8	135.26	10.5	176.79	13	217.97
28	700	711	6	118.8	9	177.45	12	235.58	15	293.22
32	800	813	6	135.99	10	225.53	13.5	303.14	17	380.06
36	900	914	8	203.57	11	278.98	15.5	391.14	19	477.6